

Una forma de representar un objeto es por medio de sus vistas,

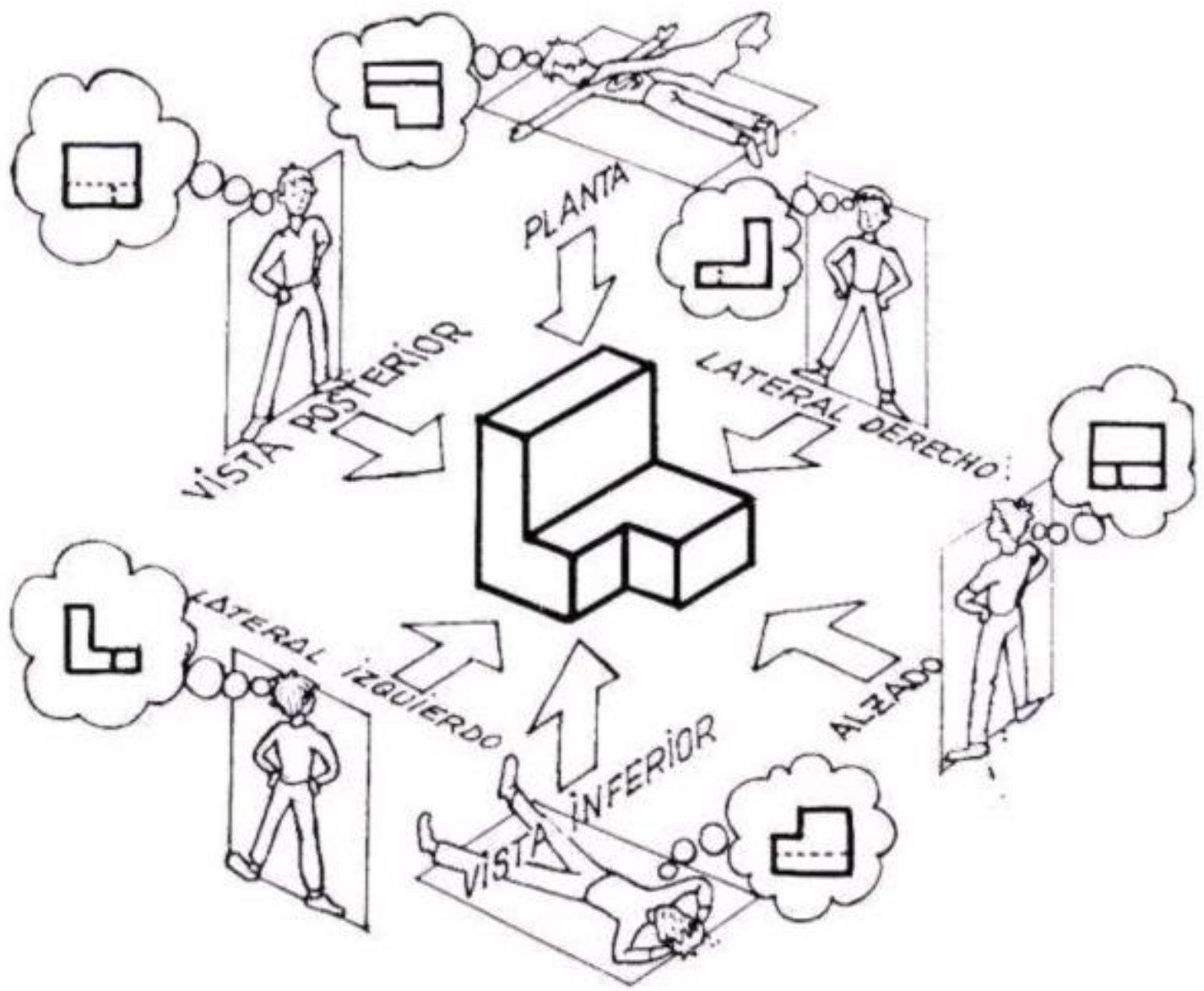

Dibujar la perspectiva isométrica a escala 1:1 de la figura representada en el Sistema Europeo por sus vistas.

NOTA: Las vistas dadas están dibujadas a la escala 1:2.

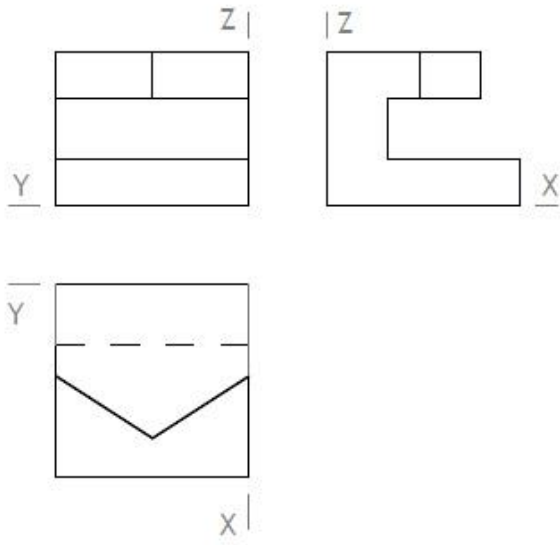

**Escala final/Escala inicial = Escala Intermedia**  
**1:1/1:2 = 2:1 sin coeficiente reducción**

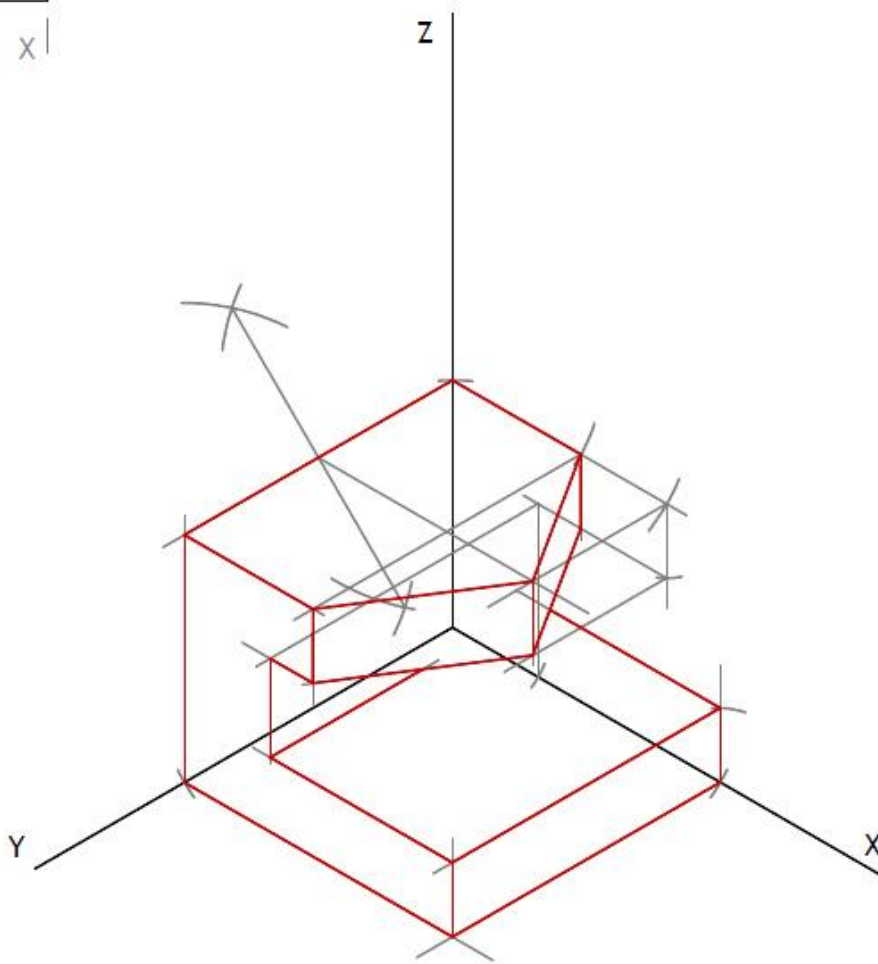

Dado un sólido por su alzado, planta y perfil en Sistema Europeo (primer diedro) y escala E=1:1, se pide realizar su perspectiva axonométrica a escala E= 3:2, considerando los ejes dados, y sabiendo que el coeficiente de reducción que hay que aplicar es de 0,816.

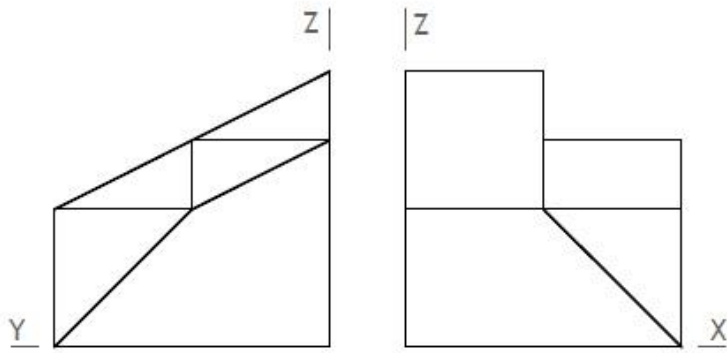

Escala final/Escala Inicial =  
Escala Intermedia

$$3:2/1:1 = 3:2 \text{ sin coef. reducción}$$

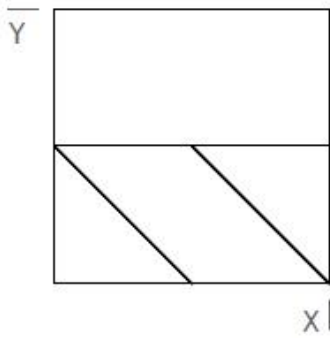

0,816 es aproximado  
a 4/5

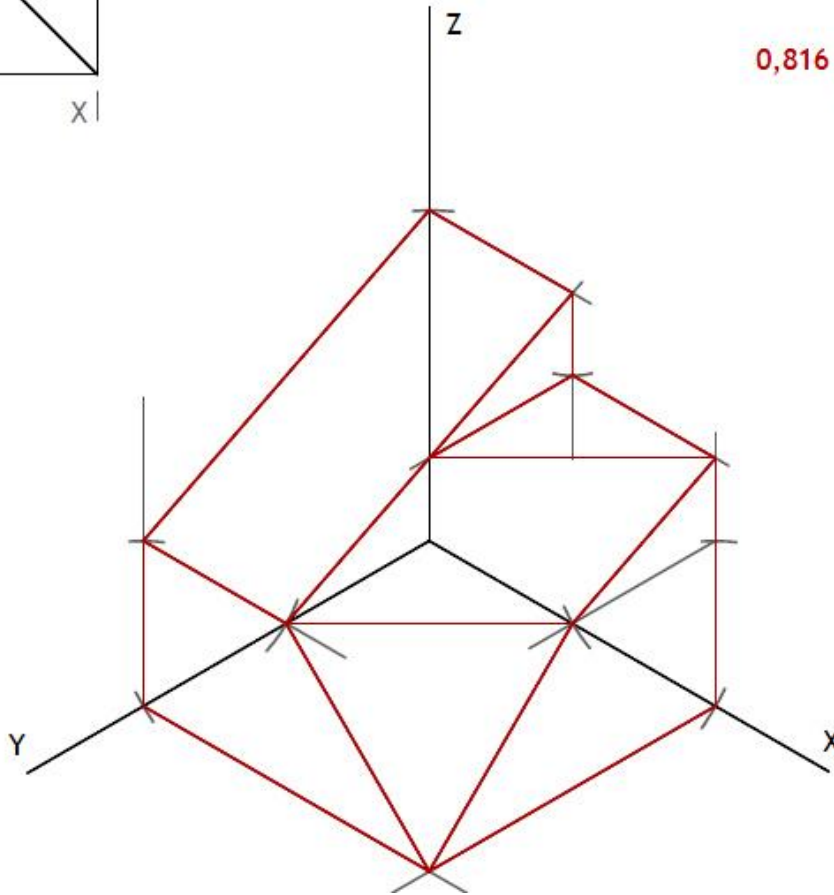

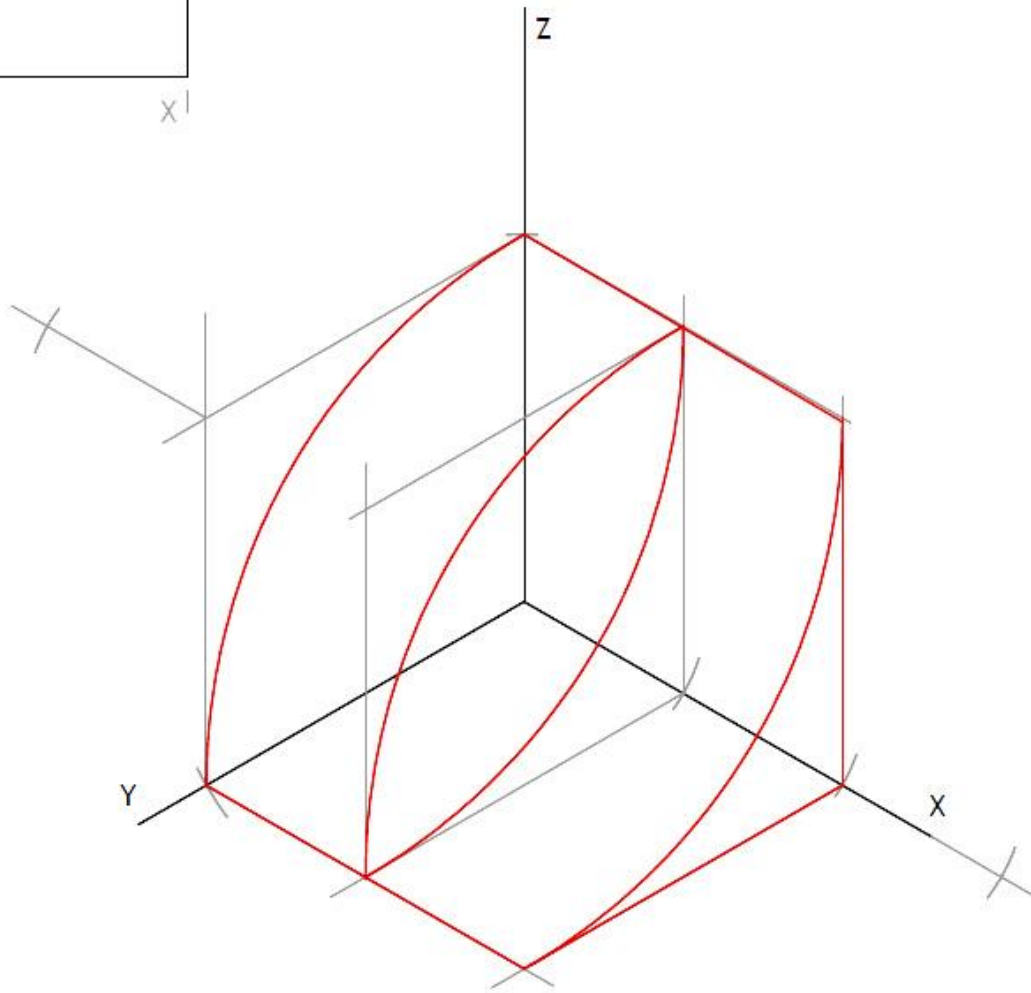
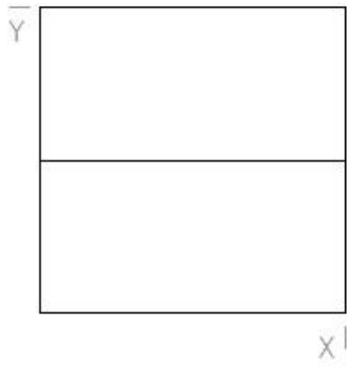
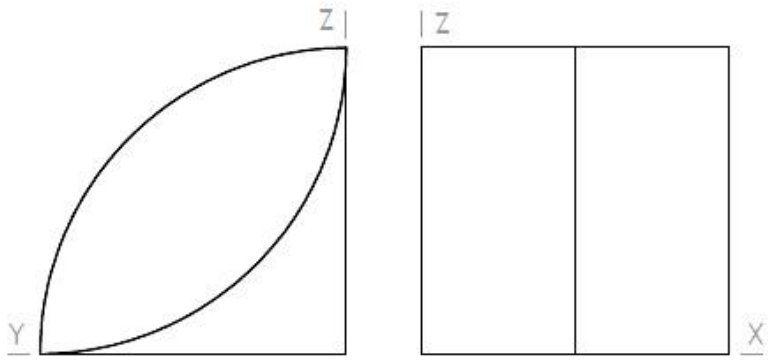

Escala Intermedia = Escala Final/Escala Inicial

1:1 / 1:2 = 2:1 sin coeficiente de reducción

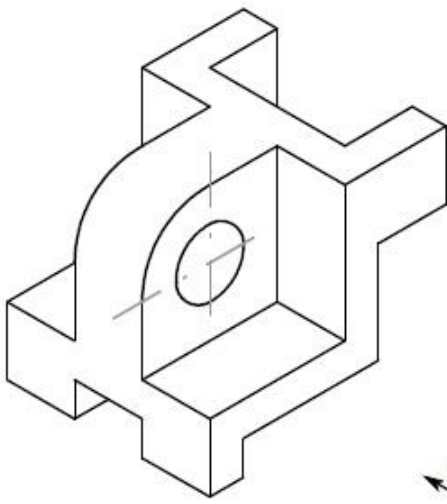

ALZADO

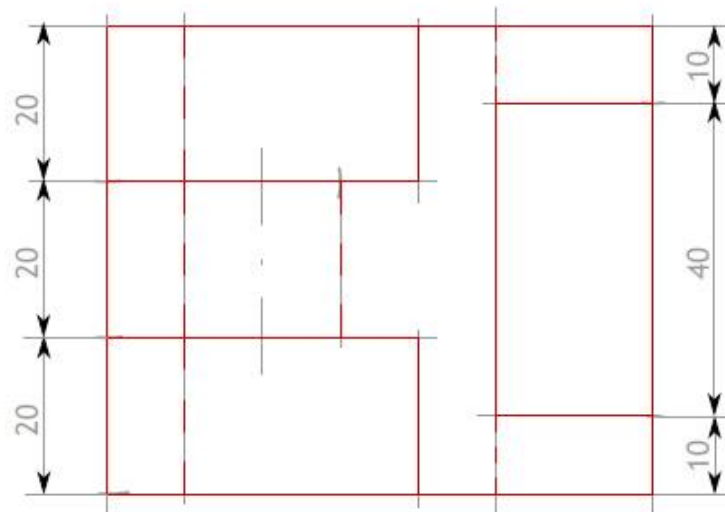
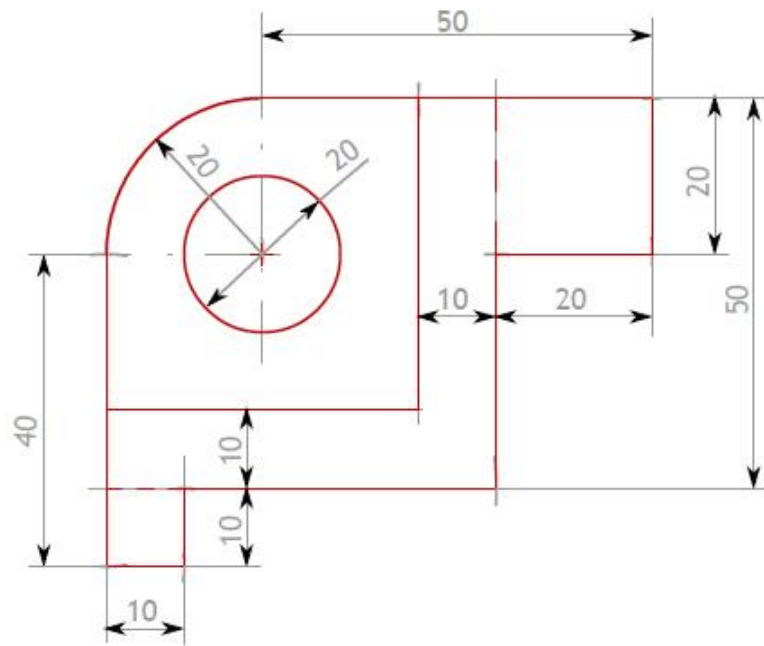

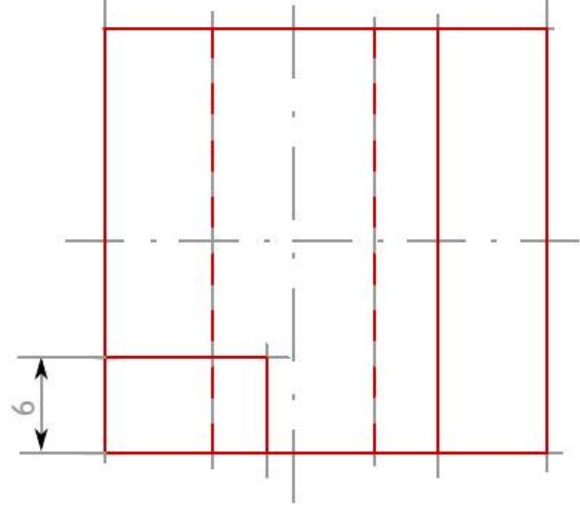
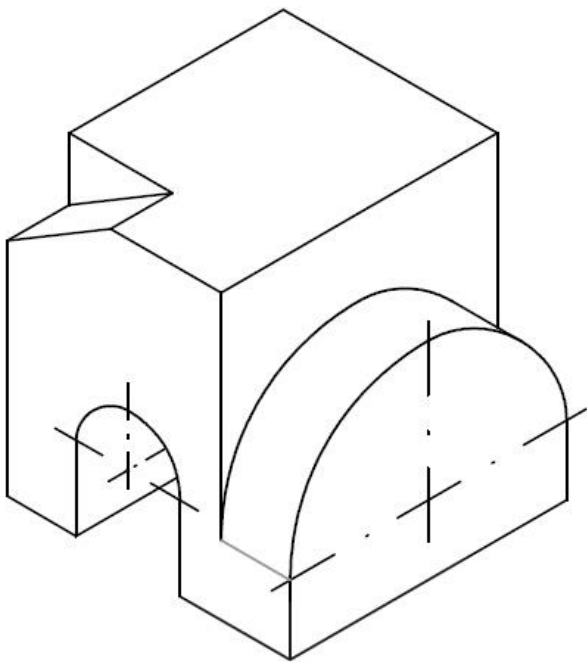
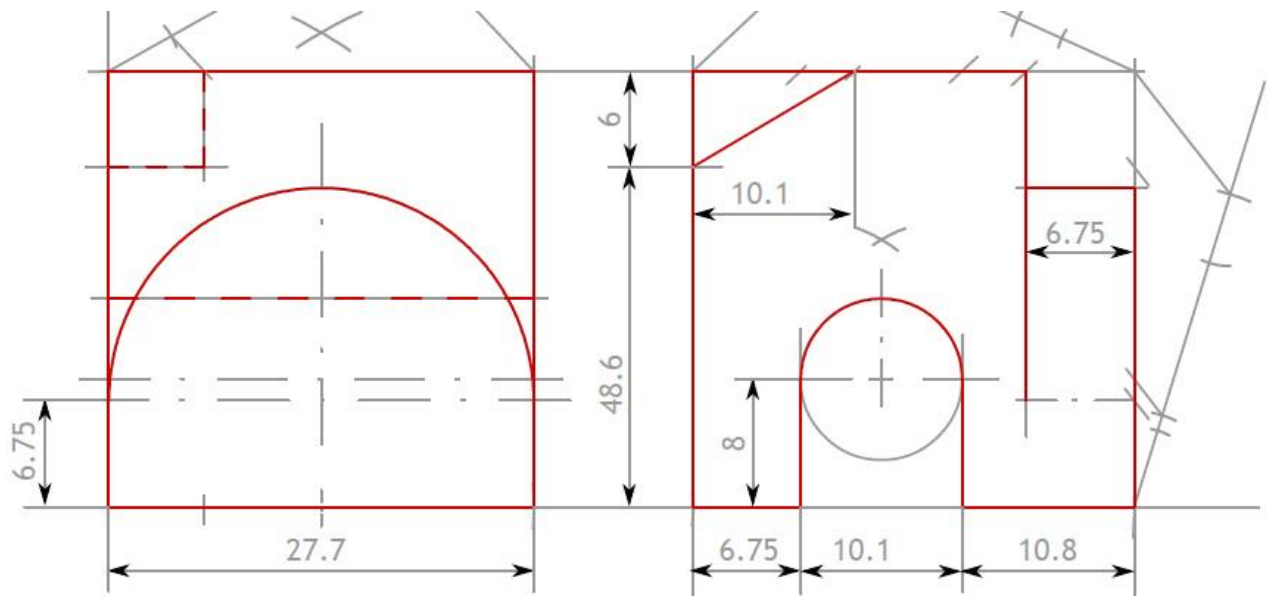

Representar su perspectiva isométrica a escala 1:1, considerando los ejes dados.

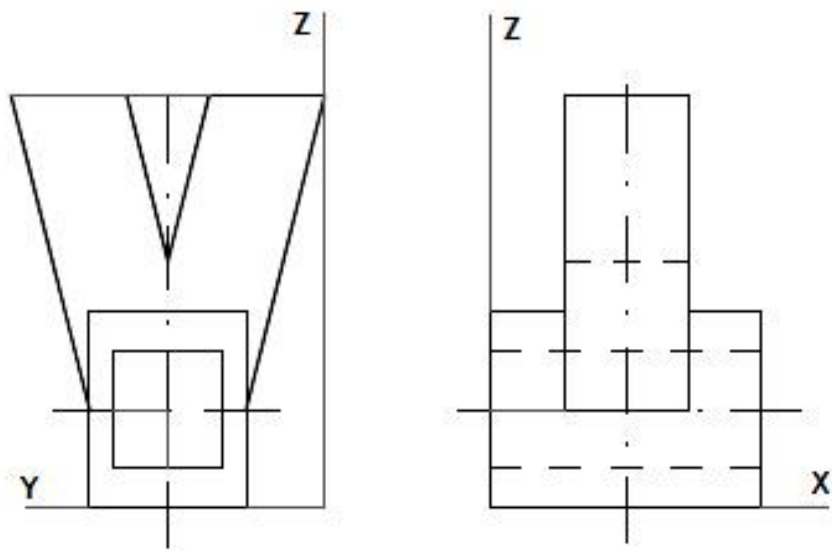

**NO SE HA APLICADO COEFICIENTE REDUCCIÓN EN LOS EJES**

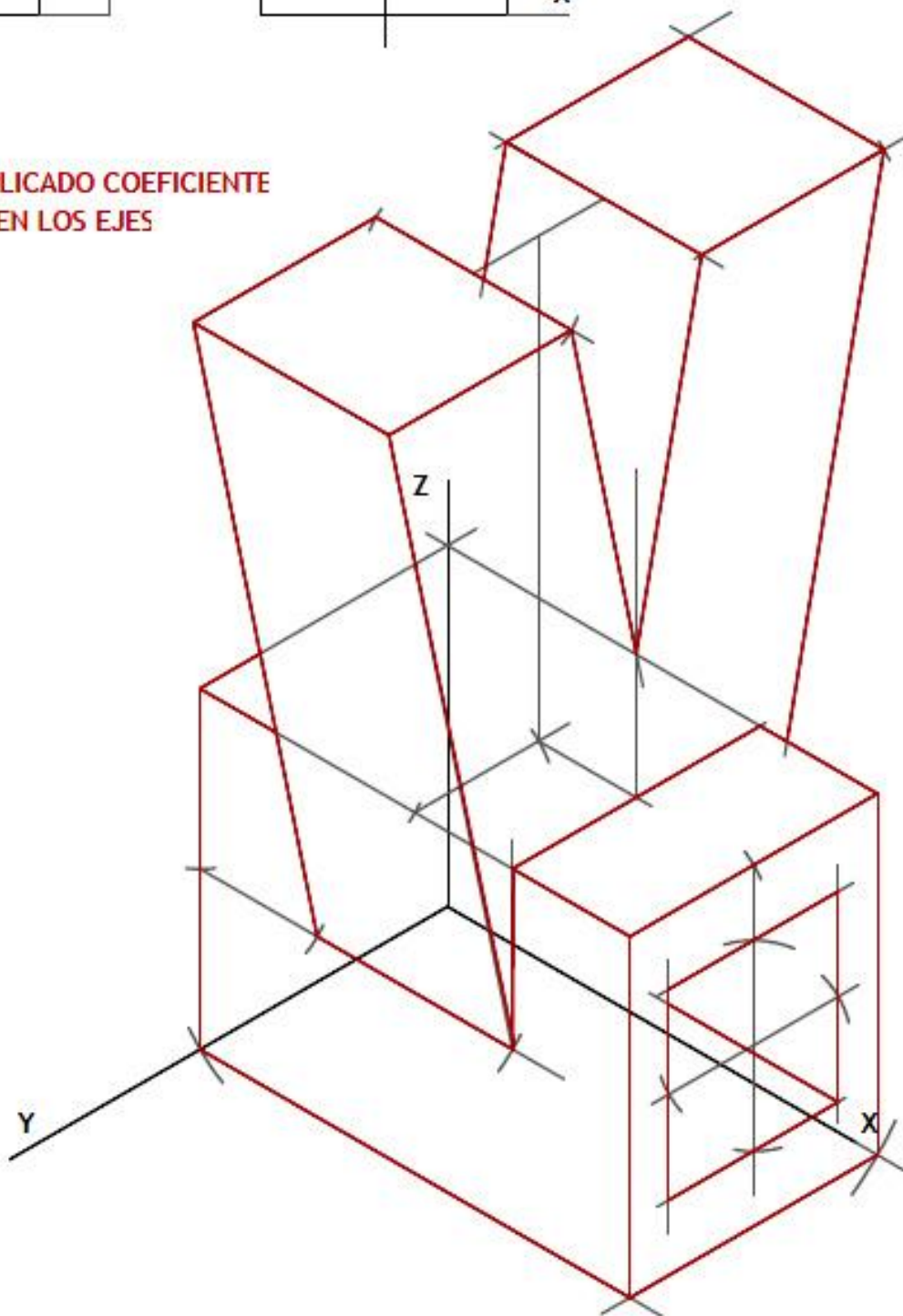

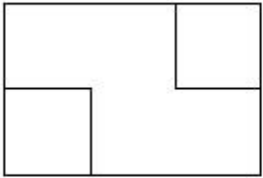
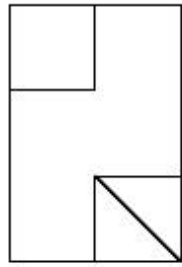
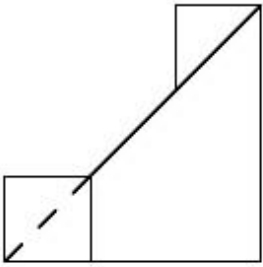

NO SE HA APLICADO COEFICIENTE DE REDUCCIÓN

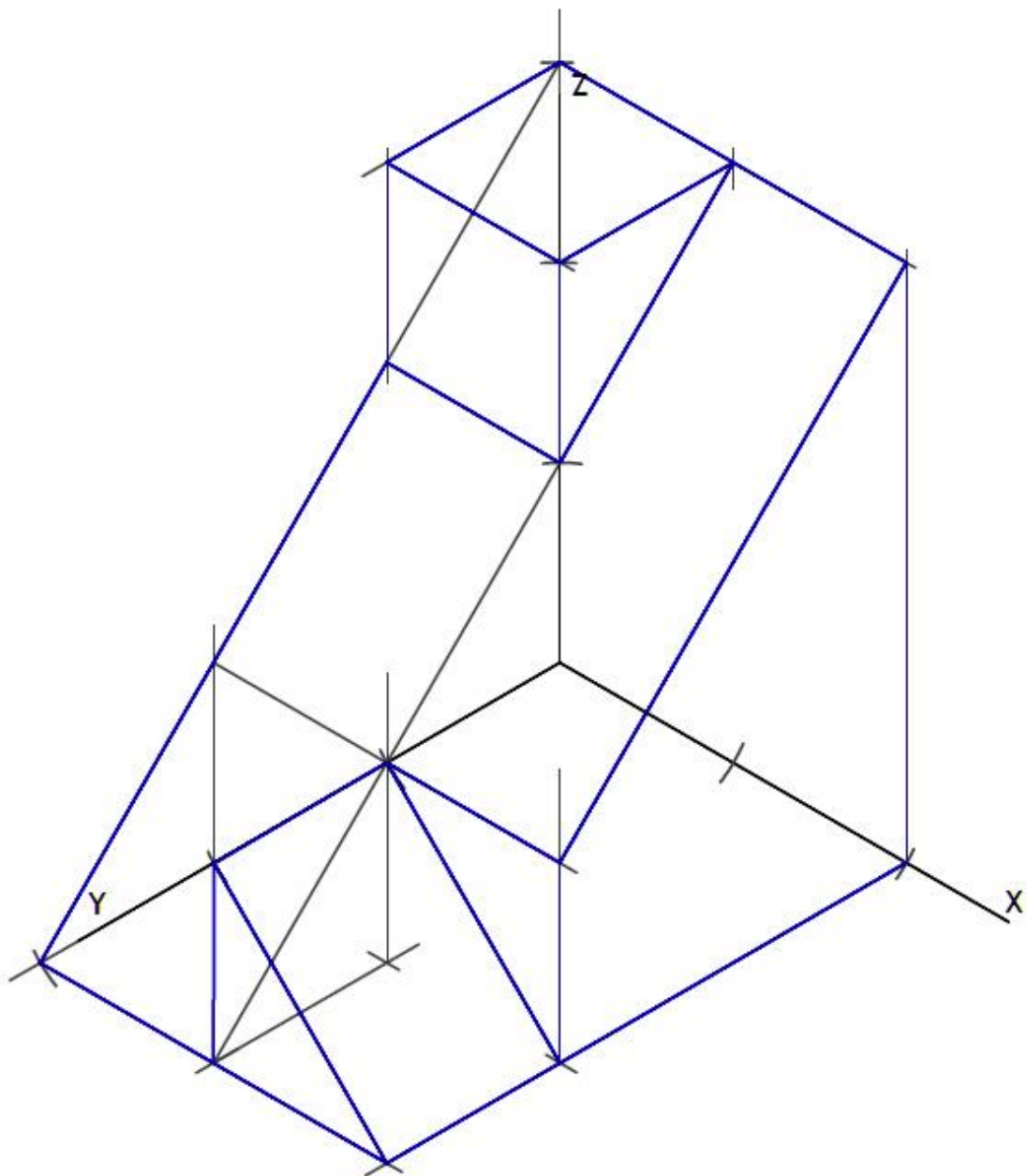



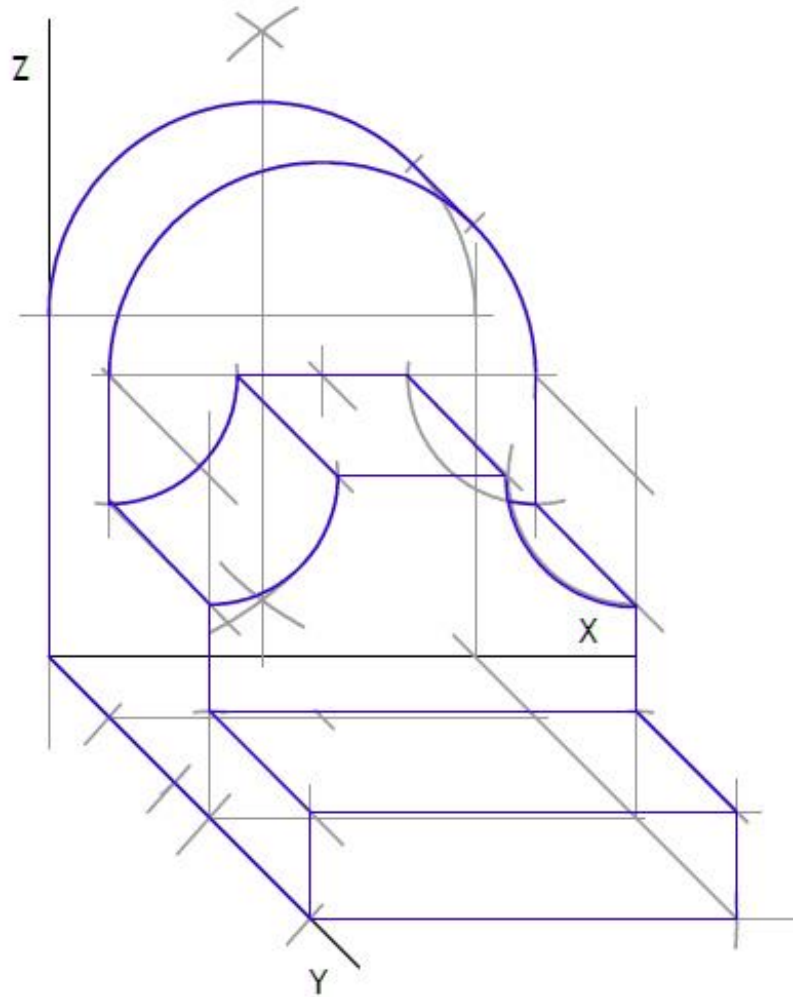
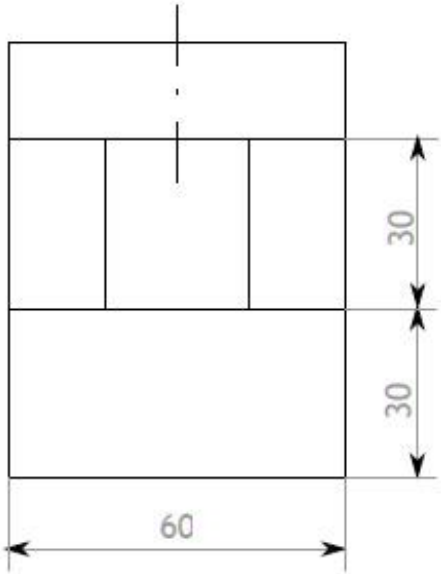
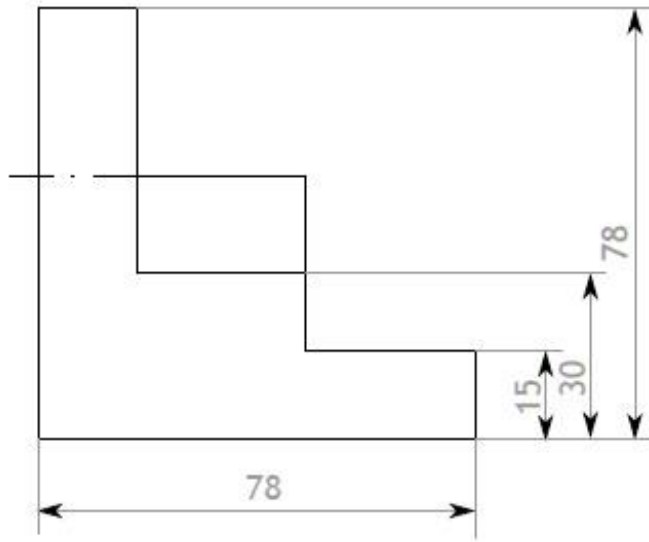
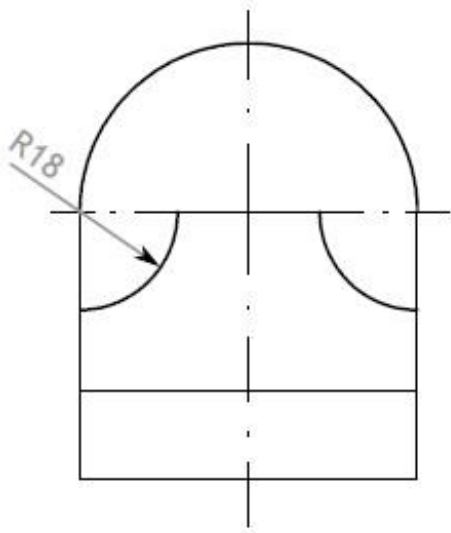

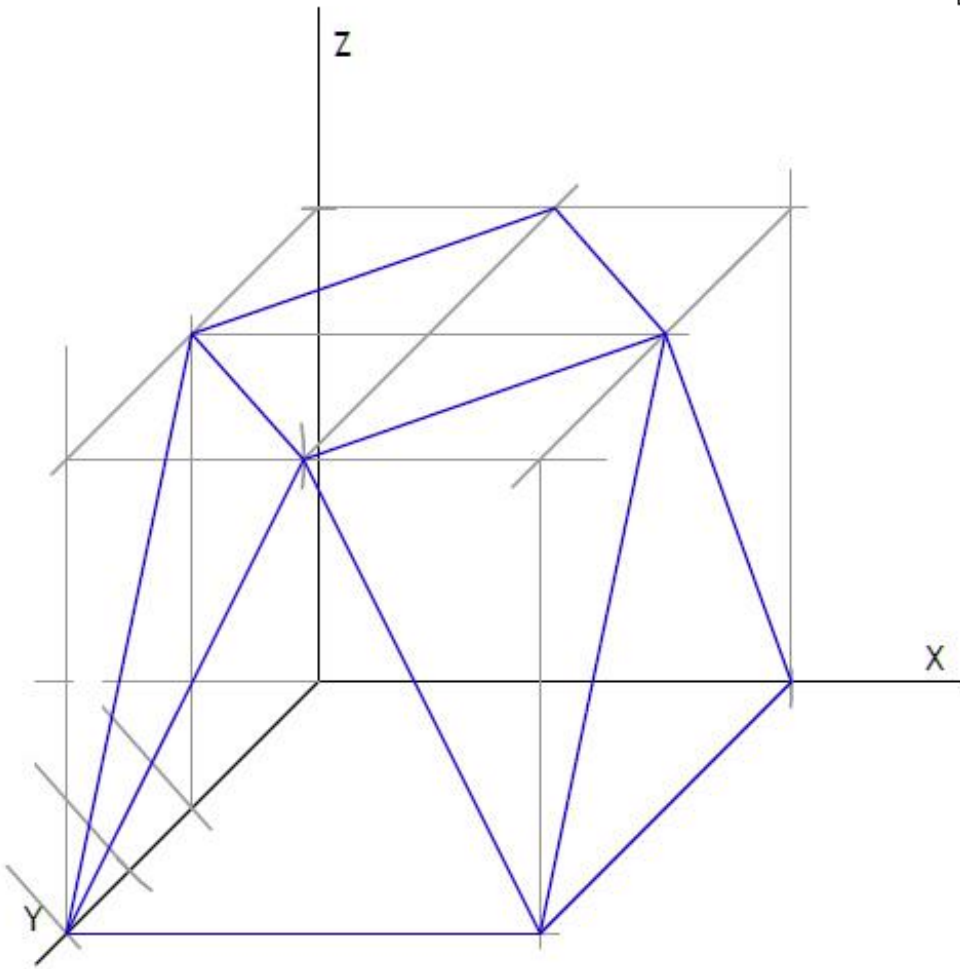
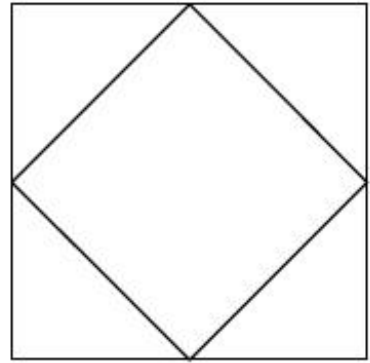
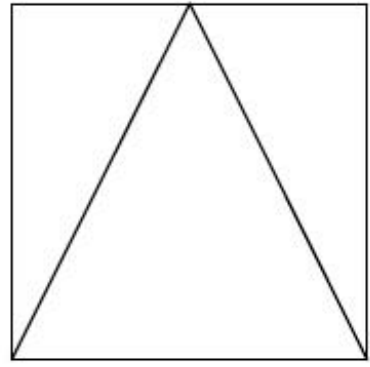
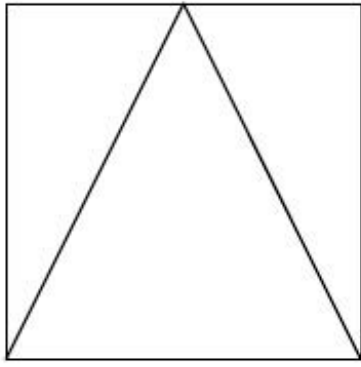

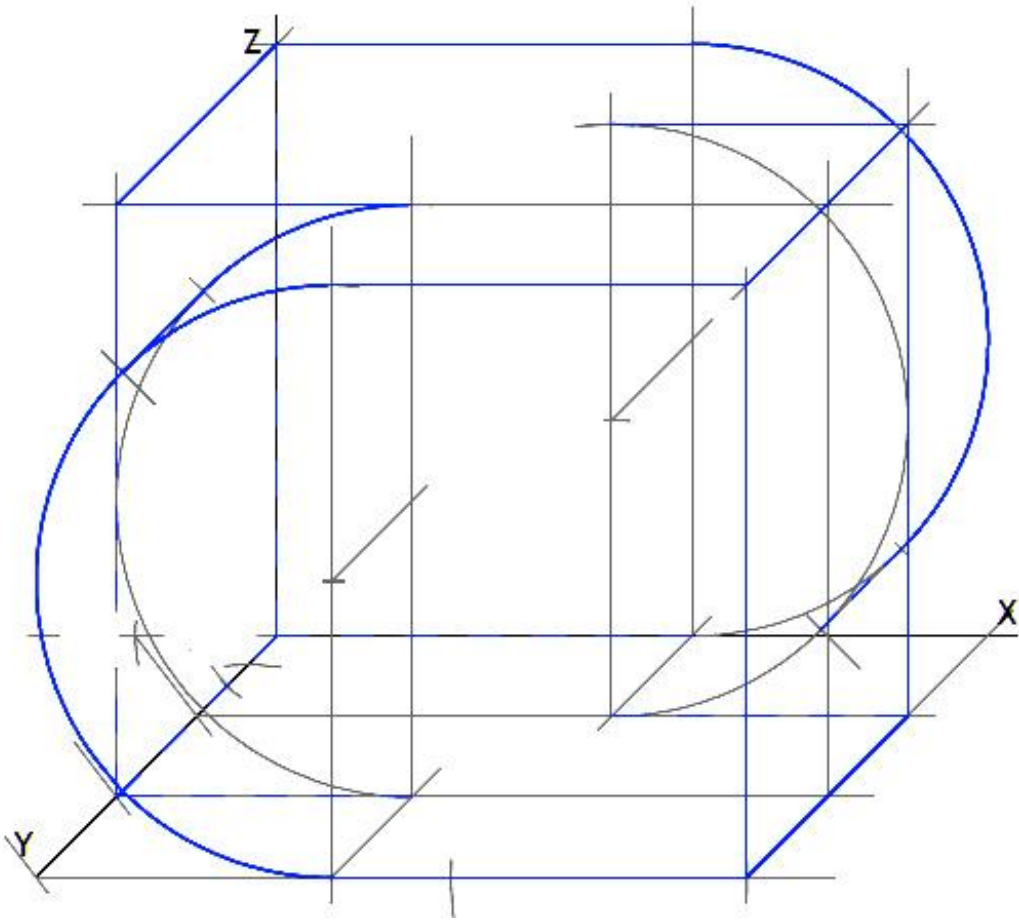
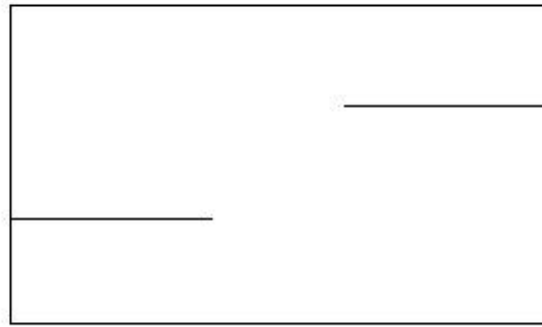
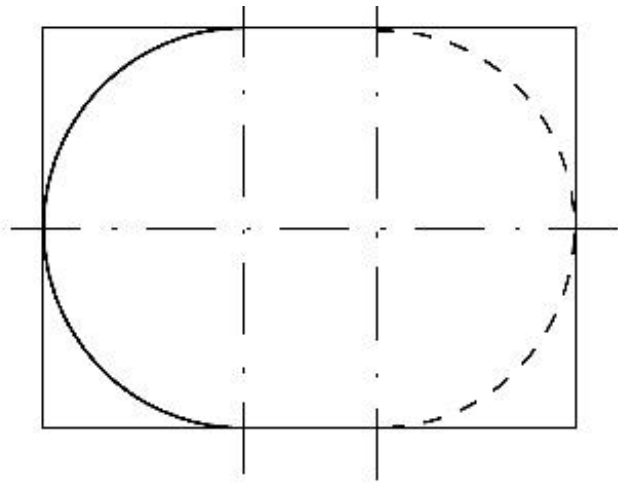
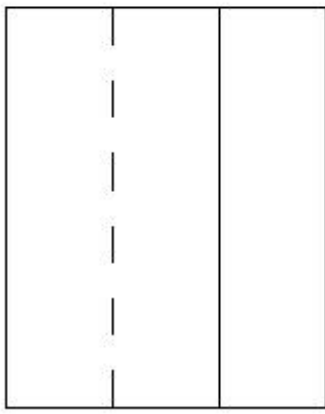

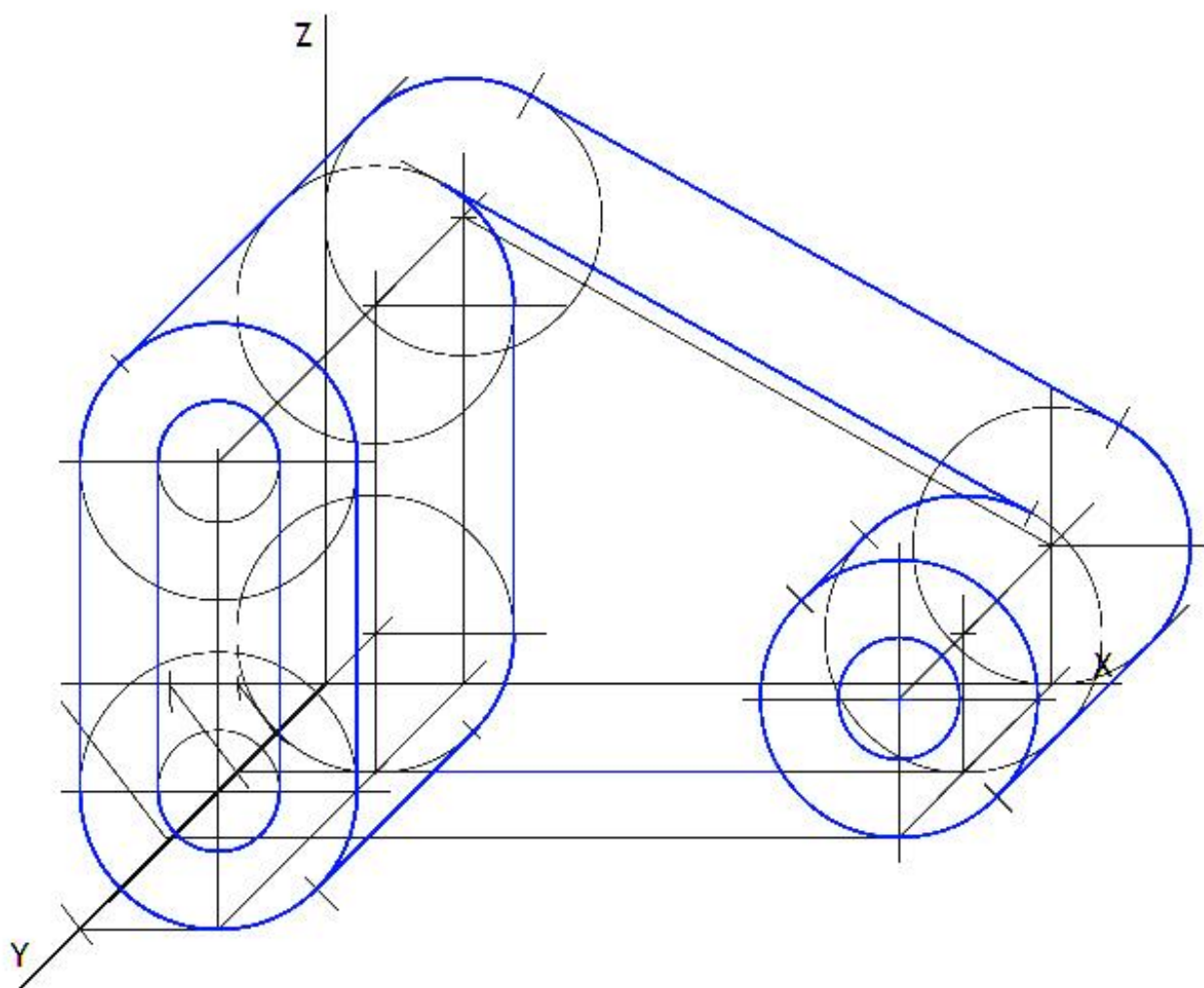
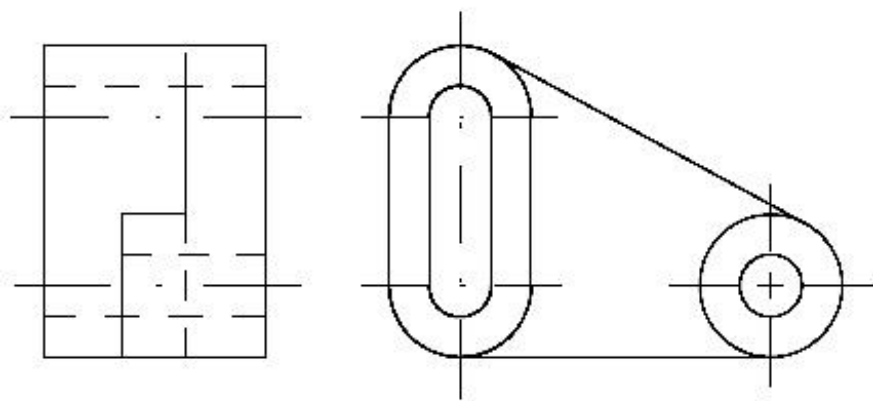

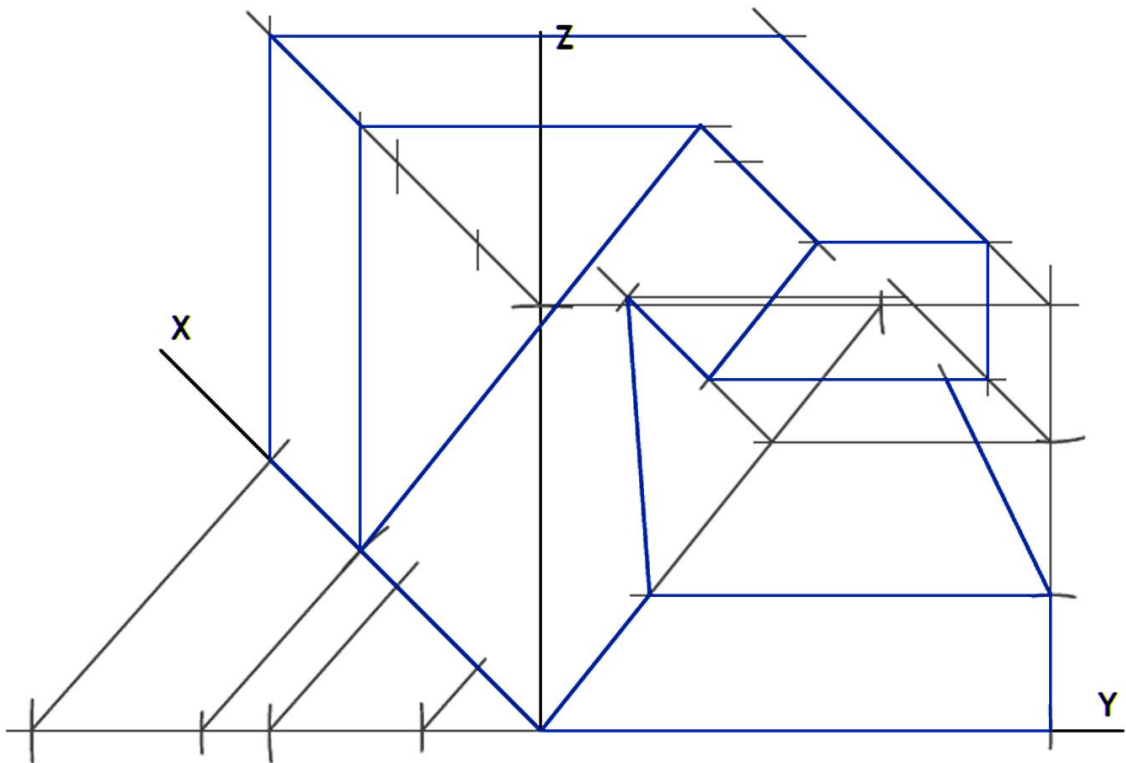
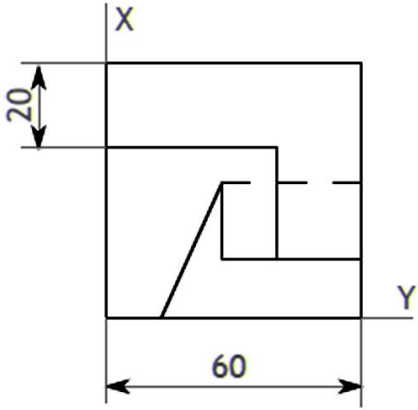
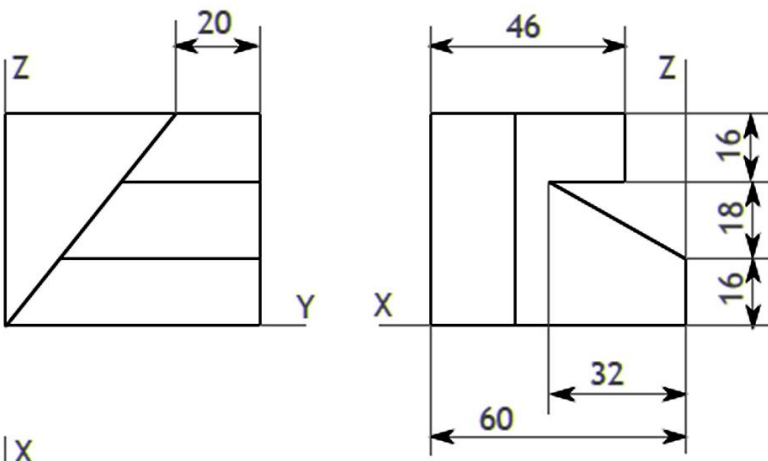

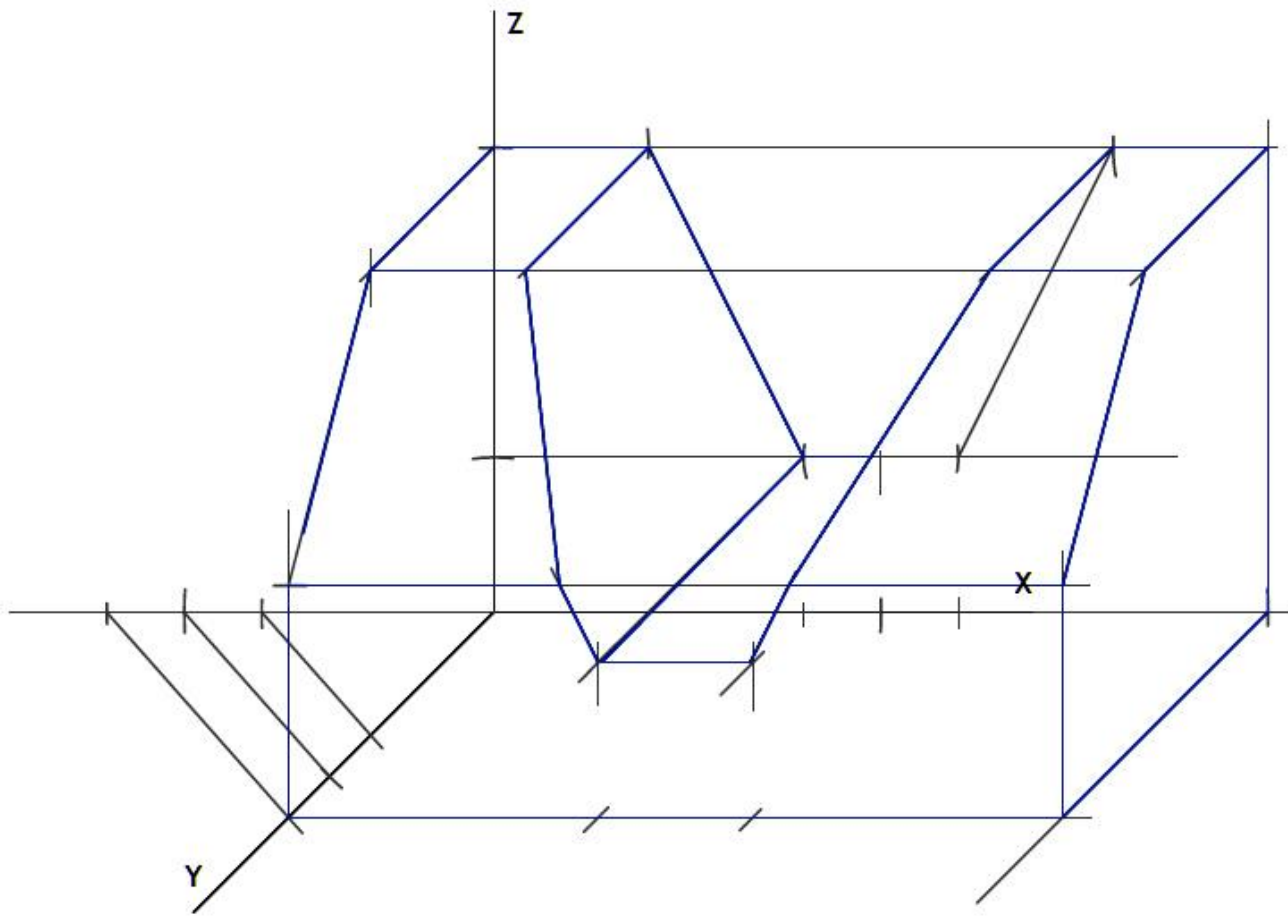
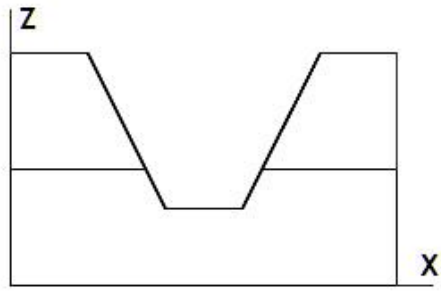
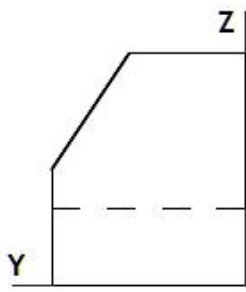

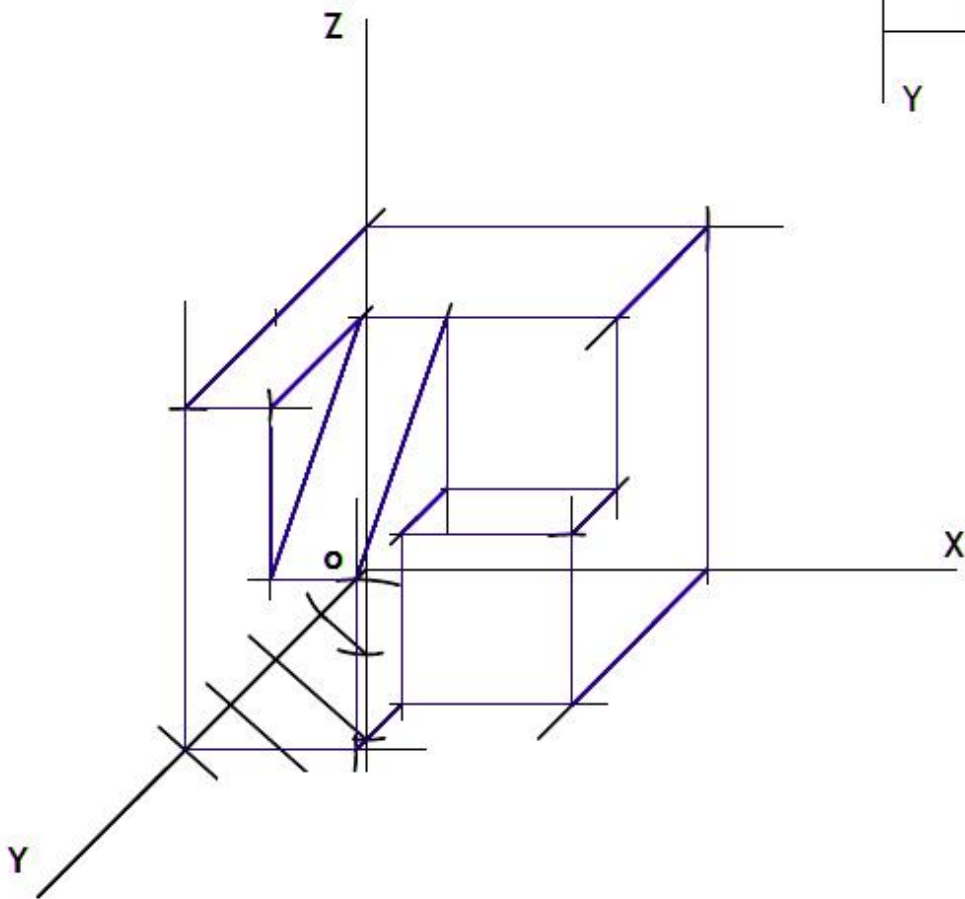
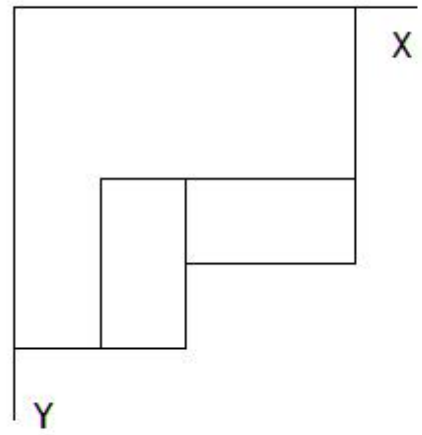
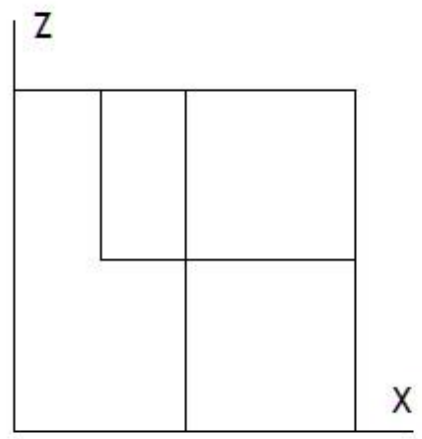
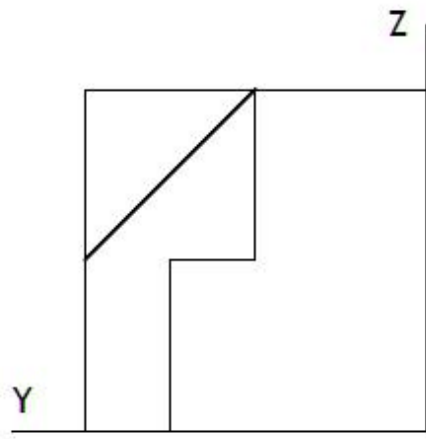

2

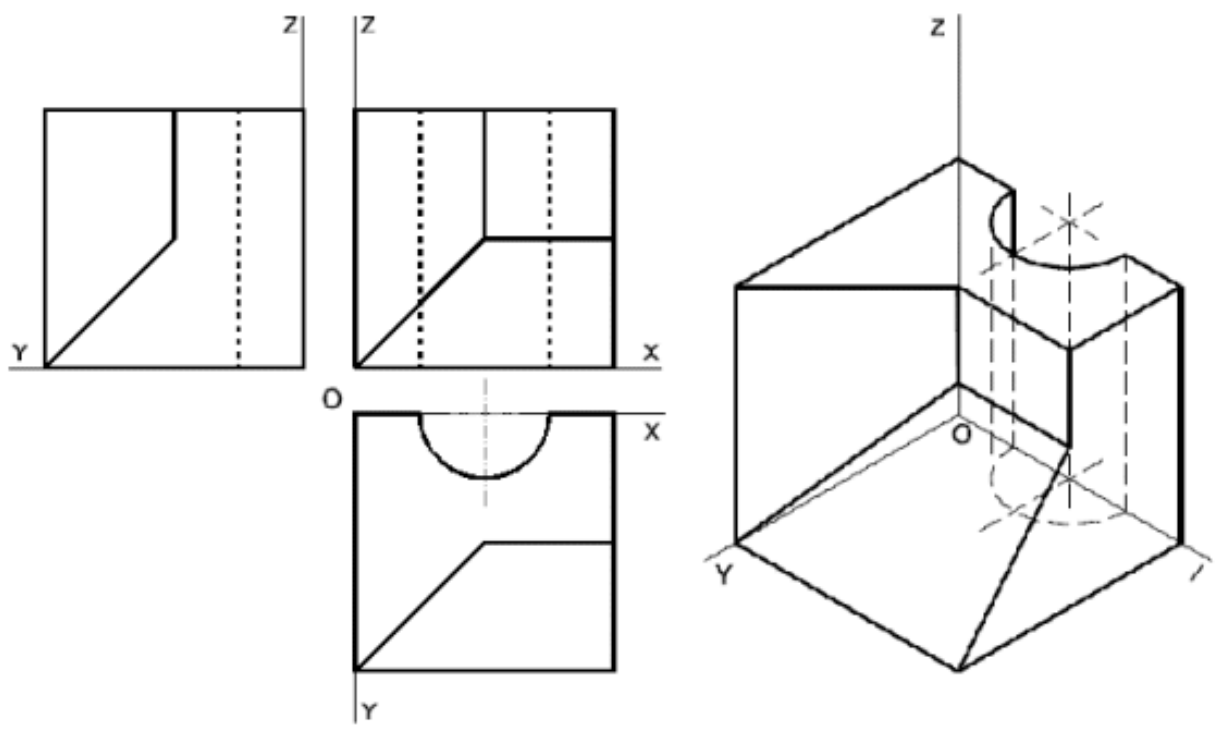

2

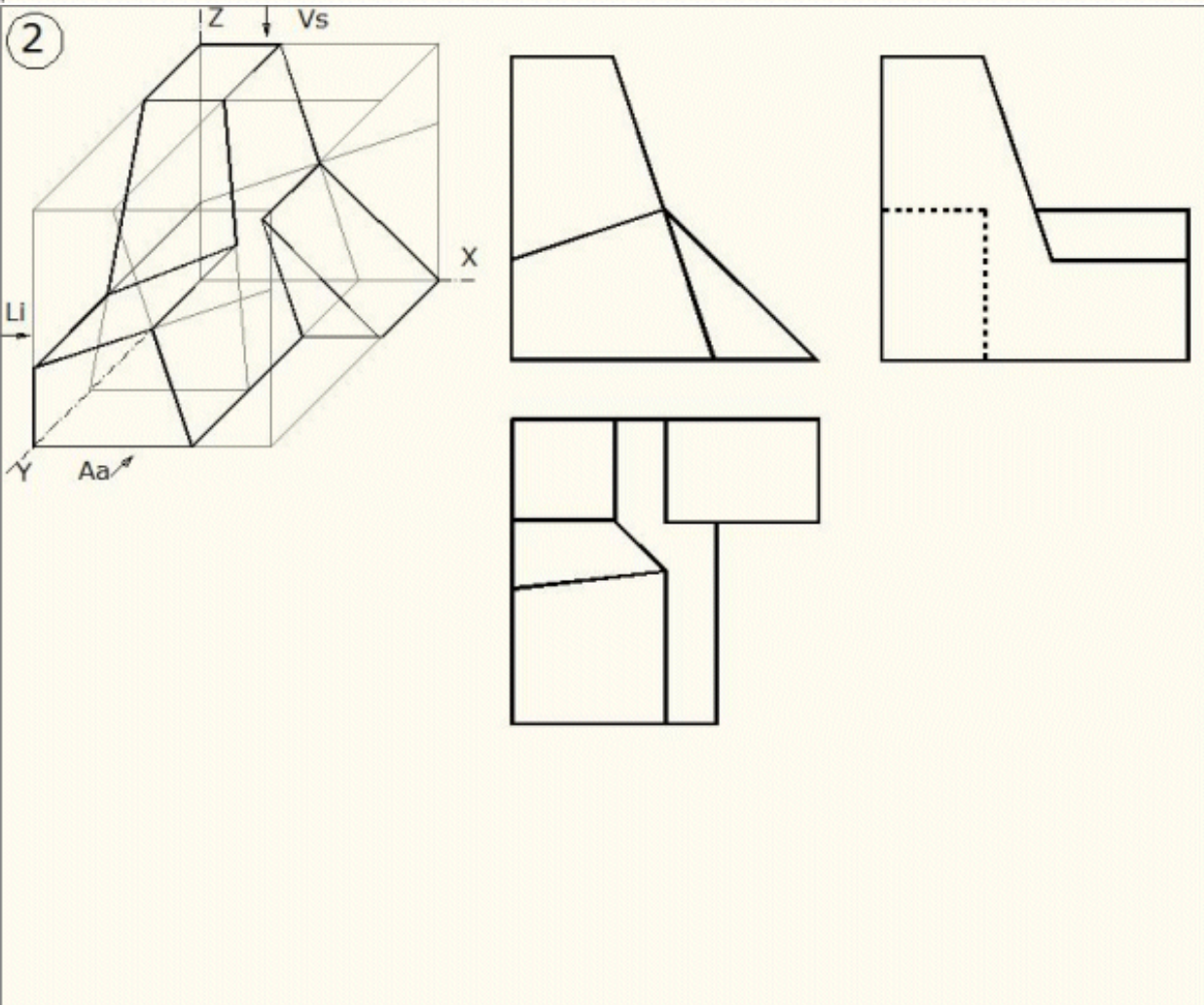



3

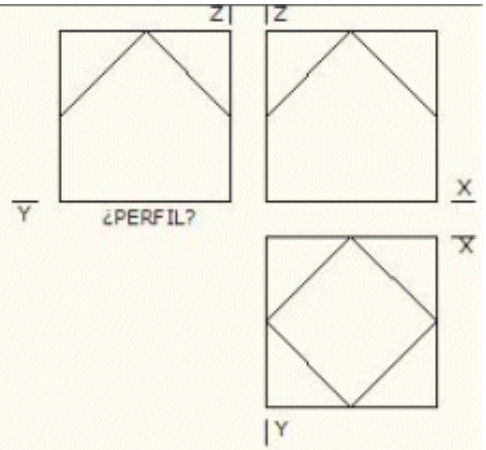
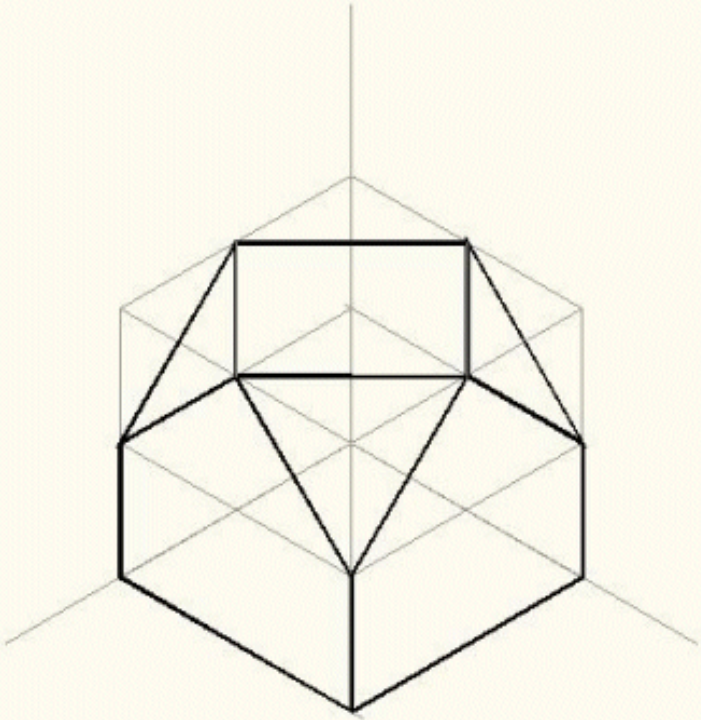

4

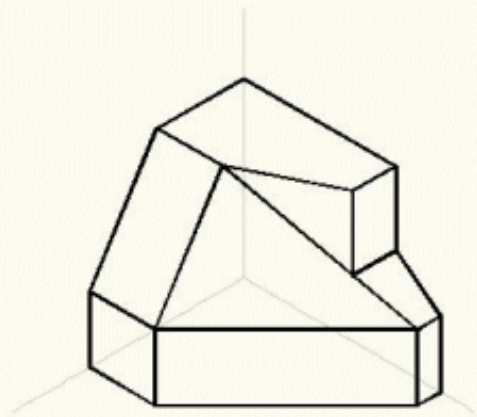
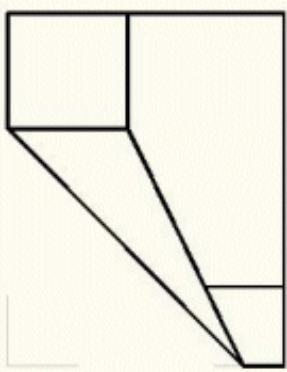
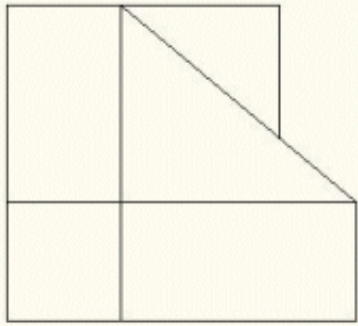
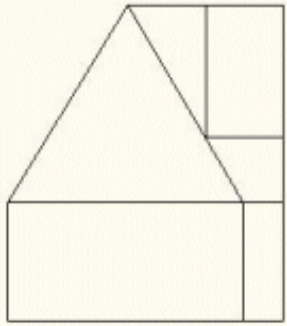

5

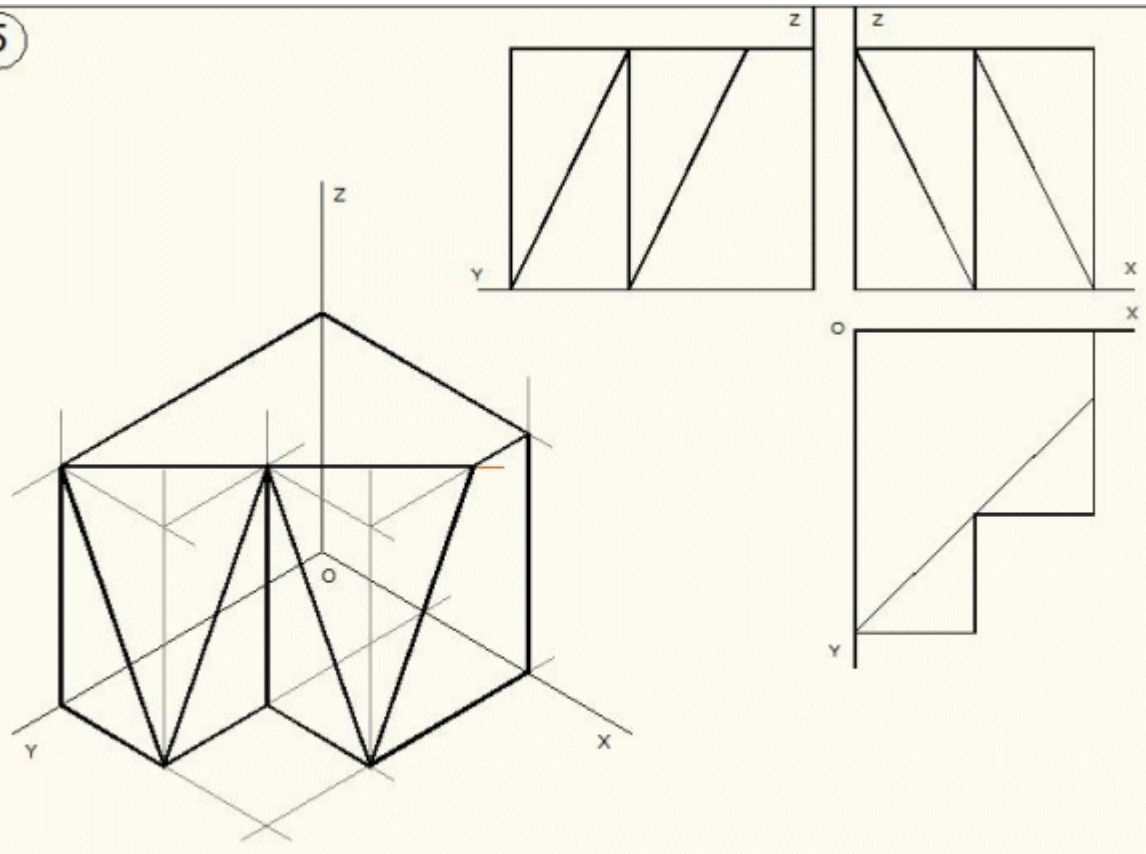

5

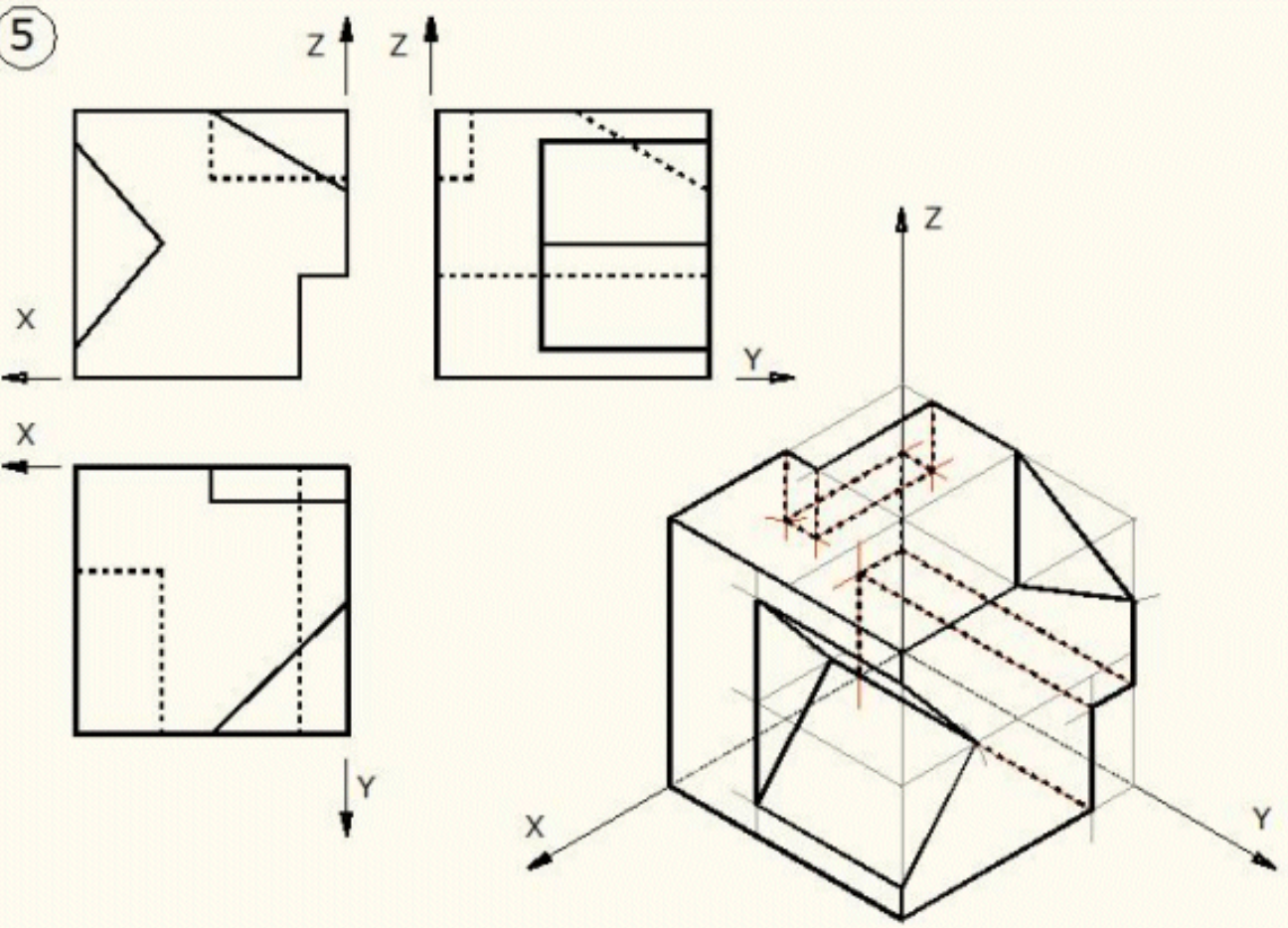

6

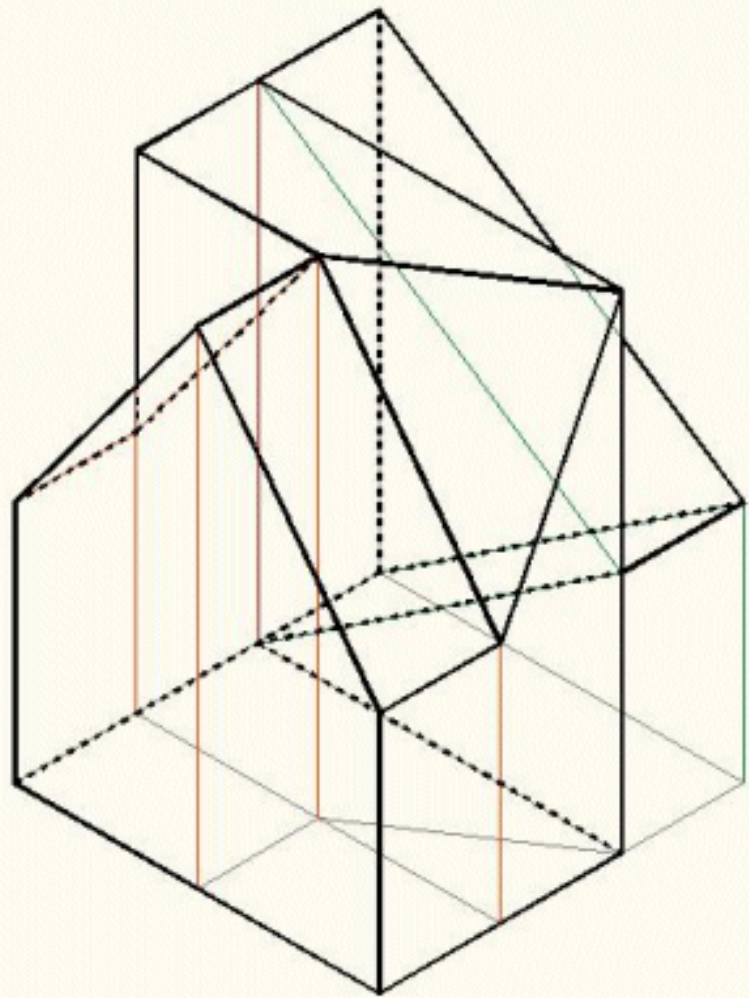
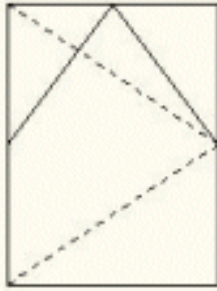

# Ejercicios resueltos en perspectiva ISOMÉTRICA

## Comprender la relación entre las vistas y la perspectiva.

Ajustándose a los ejes del Sistema que se facilitan, representar a escala 1/1 el *Dibujo Isométrico* (sin coeficiente de reducción) de la pieza dada por sus proyecciones.

Tomar las medidas de las vistas. Dibujar líneas ocultas.

Colocar la Perspectiva según la orientación de los ejes y del punto de origen (O) que se indica.

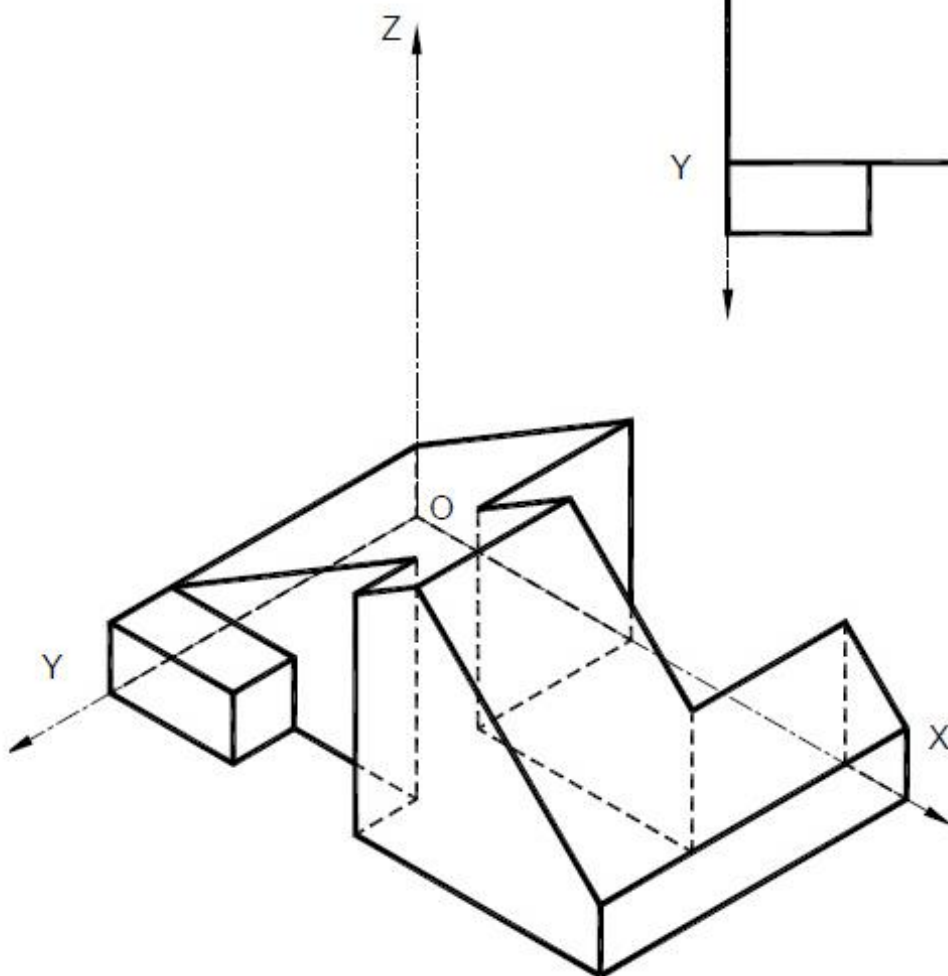
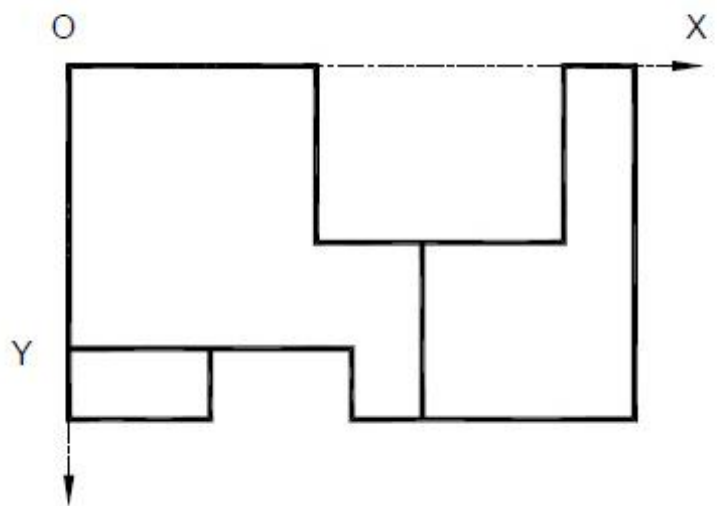
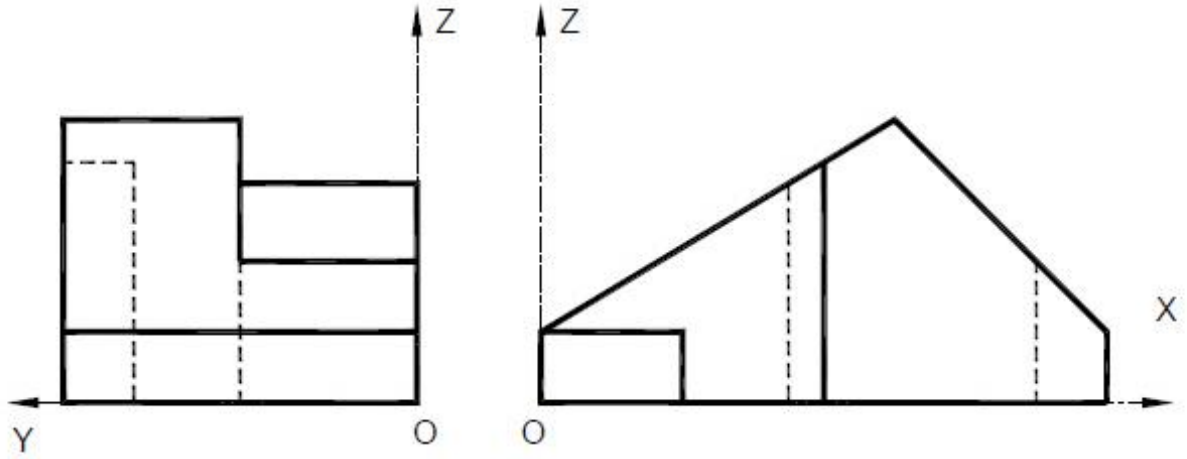

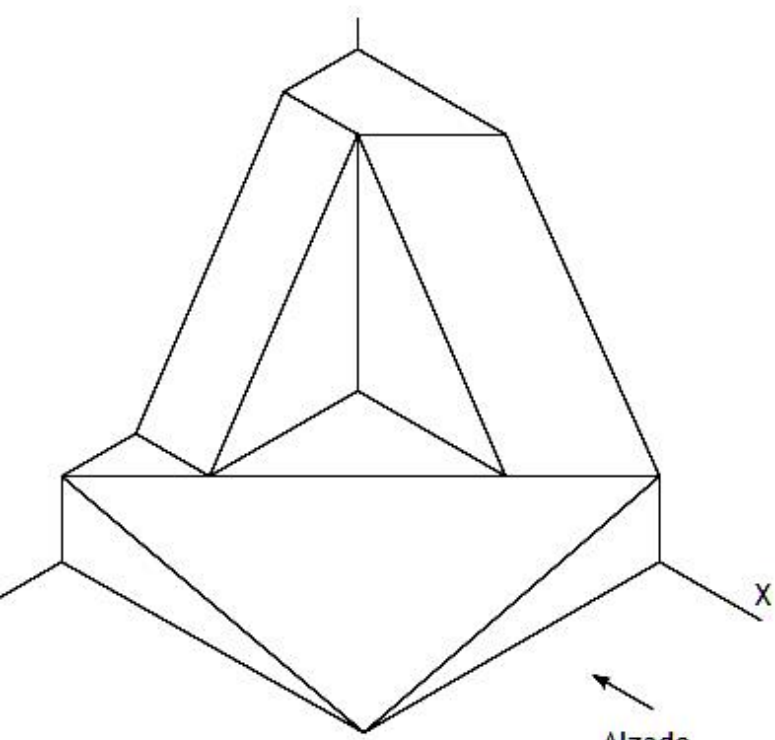

Alzado

